

SAE PORT CONTOUR CUTTERS INTERNAL STRAIGHT THREAD O-RING BOSS

CARBIDE TIPPED TAPER SHANK

MS16142/J514/J1926



Reamer pilot series porting tools profile the MS16142/J514F/J1926 contour. The reamer pilot also sizes the minor diameter per class 2B thread specification. Cutters are heat treated for toughness and durability. All tolerances are held within applicable Mil Specs. All grinding is done between centers to insure concentricity.

COATINGS AVAILABLE

**TITANIUM NITRIDE-TIN
TITANIUM CARBONITRIDE-TICN
TITANIUM ALUMINUM NITRIDE-TIALN
AL TITANIUM NITRIDE-ALTN**

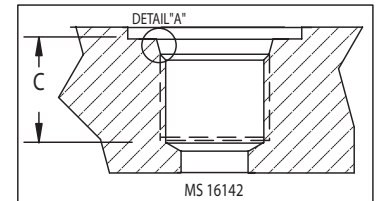
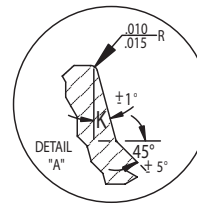
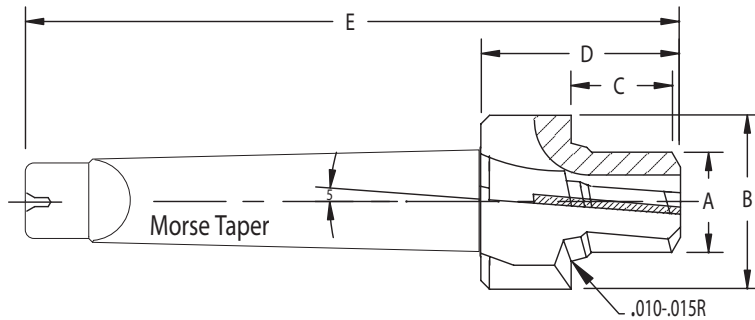

COOLANT THRU AVAILABLE

TOOL NUMBER	TUBE NO.	TUBE SIZE	THREAD SIZE	A REAMER DIA.	B SPOTFACE DIA.	C REAMER LENGTH	D HEAD LENGTH	E OAL LENGTH	K ANGLE	SHANK DIMENSIONS	
										MORSE TAPER NO.	SHANK LENGTH
TSAE-02T	2	1/8	5/16-24	.272	.682	.473	1-5/8	4-3/4	12	2MT	3-1/8
TSAE-03T	3	3/16	3/8-24	.335	.760	.473	1-5/8	4-3/4	12	2MT	3-1/8
TSAE-04T	4	1/4	7/16-20	.389	.838	.552	1-5/8	4-3/4	12	2MT	3-1/8
TSAE-05T	5	5/16	1/2-20	.452	.916	.552	1-5/8	4-3/4	12	2MT	3-1/8
TSAE-06T	6	3/8	9/16-18	.509	.979	.614	1-5/8	4-3/4	12	2MT	3-1/8
TSAE-08T	8	1/2	3/4-16	.689	1.198	.693	1-3/4	5-5/8	15	3MT	3-7/8
TSAE-10T	10	5/8	7/8-14	.806	1.354	.786	1-7/8	5-3/4	15	3MT	3-7/8
TSAE-12T	12	3/4	1-1/16-12	.981	1.635	.911	2	5-7/8	15	3MT	3-7/8
TSAE-14T	14	7/8	1-3/16-12	1.106	1.775	.911	2	5-7/8	15	3MT	3-7/8
TSAE-16T	16	1"	1-5/16-12	1.231	1.920	.911	2	5-7/8	15	3MT	3-7/8
TSAE-20T	20	1-1/4	1-5/8-12	1.544	2.280	.911	2-1/4	7-1/8	15	4MT	4-7/8
TSAE-24T	24	1-1/2	1-7/8-12	1.794	2.570	.911	2-1/4	7-1/8	15	4MT	4-7/8
TSAE-32T	32	2	2-1/2-12	2.419	3.490	.911	2-1/4	7-1/8	15	4MT	4-7/8

