

BRITISH STANDARD PARALLEL PIPE "G" STYLE BSPP

CARBIDE TIPPED STRAIGHT SHANK

BSPP Cutters will ream and chamfer in a pre-drilled or pre-cast hole for thread "G", and form in one pass the contour of Type "O" or Type "E" depending on the application and seal method selected. Cutters are heat treated for toughness and durability. All grinding is done between centers to insure concentricity.

COATINGS AVAILABLE

TITANIUM NITRIDE-TIN
TITANIUM CARBONITRIDE-TICN
TITANIUM ALUMINUM NITRIDE-TIALN
AL TITANIUM NITRIDE-ALTN

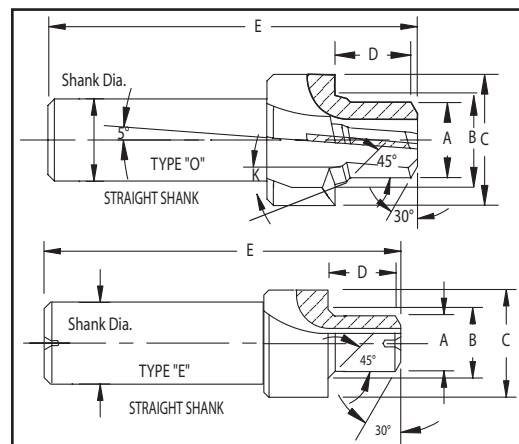

"G" STYLE BSPP • TYPE "O" • O RING SEAL METHOD • CARBIDE TIPPED **COOLANT THRU AVAILABLE**

TOOL NUMBER	NOMINAL SIZE G	A SMALL DIA.	B CHAMFER DIA.	C SPOTFACE DIA.	D REAMER LENGTH	E OAL LENGTH	SHANK DIMENSIONS		K ANGLE
							DIAMETER	LENGTH	
BS012-TG0	1/8	.343	.459	.709	.590	3-3/16	.500	2.0	12
BS025-TG0	1/4	.460	.616	.945	.708	3-1/2	.500	2.0	12
BS037-TG0	3/8	.598	.734	1.102	.708	3-1/2	.500	2.0	12
BS050-TG0	1/2	.745	.890	1.339	.945	3-11/16	.750	2.0	15
BS075-TG0	3/4	.962	1.175	1.716	.984	4-1/4	.750	2.0	15
BS100-TG0	1	1.206	1.411	2.008	1.181	4-1/4	.750	2.0	15
BS125-TG0	1-1/4	1.547	1.766	2.441	1.181	5	1.000	2.5	15
BS150-TG0	1-1/2	1.779	2.002	2.677	1.181	5-1/8	1.000	2.5	15

"G" STYLE BSPP • TYPE "E" • EDGE SEAL METHOD • CARBIDE TIPPED **COOLANT THRU AVAILABLE**

TOOL NUMBER	NOMINAL SIZE G	A SMALL DIA.	B CHAMFER DIA.	C SPOTFACE DIA.	D REAMER LENGTH	E OAL LENGTH	SHANK DIMENSIONS		NO. OF FLUTES
							DIAMETER	LENGTH	
BS012-TGE	1/8	.343	.400	.591	.590	3-3/16	.500	2.0	3
BS025-TGE	1/4	.460	.535	.748	.708	3-1/2	.500	2.0	3
BS037-TGE	3/8	.598	.676	.906	.708	3-1/2	.500	2.0	3
BS050-TGE	1/2	.745	.845	1.063	.945	3-11/16	.750	2.0	3
BS075-TGE	3/4	.962	1.065	1.299	.984	4-1/4	.750	2.0	3
BS100-TGE	1	1.206	1.335	1.575	1.181	4-1/4	.750	2.0	3
BS125-TGE	1-1/4	1.547	1.675	1.968	1.181	5	1.000	2.5	4
BS150-TGE	1-1/2	1.779	1.906	2.205	1.181	5-1/8	1.000	2.5	4

Cutters can be altered to meet your requirements.

