

# BRITISH STANDARD PARALLEL PIPE BSPP

# CARBIDE TIPPED STRAIGHT SHANK

BSPP Cutters will ream and chamfer in one pass in a pre-drilled or pre-cast hole for a parallel pipe thread. Cutters are heat treated for toughness and durability. All grinding is done between centers to insure concentricity.

COATINGS AVAILABLE
TITANIUM NITRIDE-TIN
TITANIUM CARBONITRIDE-TICN
TITANIUM ALUMINUM NITRIDE-TIALN
AL TITANIUM NITRIDE-ALTiN

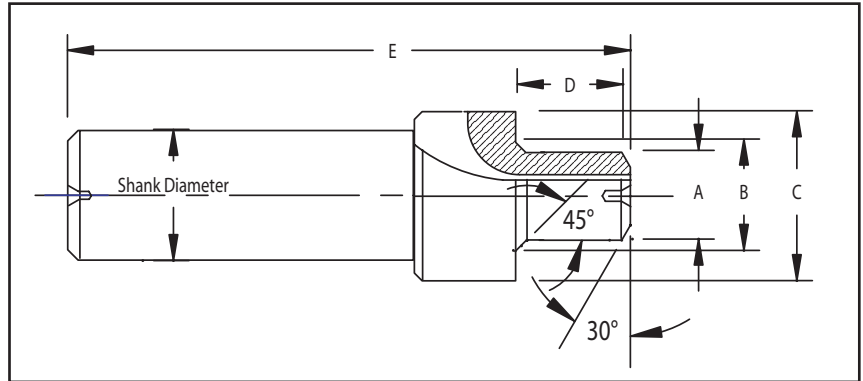

## STANDARD REAMER LENGTH—CARBIDE TIPPED COOLANT THRU AVAILABLE

TOOL NUMBER	THREAD SIZE	A SMALL DIA.	B CHAMFER DIA.	C SPOTFACE DIA.	D REAMER LENGTH	E OAL LENGTH	SHANK DIMENSIONS		NO. OF FLUTES
							DIAMETER	LENGTH	
BS012-T	1/8-28	.343	.400	.656	.536	3-3/16	.500	2.0	3
BS025-T	1/4-19	.460	.535	.827	.762	3-1/2	.500	2.0	3
BS037-T	3/8-19	.598	.676	1.000	.762	3-1/2	.500	2.0	3
BS050-T	1/2-14	.745	.845	1.188	.916	3-11/16	.750	2.0	3
BS075-T	3/4-14	.962	1.065	1.438	.995	4-1/4	.750	2.0	3
BS0100-T	1-11	1.206	1.335	1.812	1.151	4-1/4	.750	2.0	3
BS125-T	1-1/4-11	1.547	1.675	2.086	1.230	5	1.000	2.5	4
BS150-T	1-1/2-11	1.779	1.906	2.323	1.310	5-1/8	1.000	2.5	4

## SHORT REAMER LENGTH—CARBIDE TIPPED COOLANT THRU AVAILABLE

TOOL NUMBER	THREAD SIZE	A SMALL DIA.	B CHAMFER DIA.	C SPOTFACE DIA.	D REAMER LENGTH	E OAL LENGTH	SHANK DIMENSIONS		NO. OF FLUTES
							DIAMETER	LENGTH	
BS012-ST	1/8-28	.343	.400	.656	.372	3-3/16	.500	2.0	3
BS025-ST	1/4-19	.460	.535	.827	.516	3-1/2	.500	2.0	3
BS037-ST	3/8-19	.598	.676	1.000	.516	3-1/2	.500	2.0	3
BS050-ST	1/2-14	.745	.845	1.188	.660	3-11/16	.750	2.0	3
BS075-ST	3/4-14	.962	1.065	1.438	.756	4-1/4	.750	2.0	3
BS100-ST	1-11	1.206	1.335	1.812	.900	4-1/4	.750	2.0	3
BS125-ST	1-1/4-11	1.547	1.675	2.086	.996	5	1.000	2.5	4
BS150-ST	1-1/2-11	1.779	1.906	2.323	.996	5-1/8	1.000	2.5	4

*Cutters can be altered to meet your requirements.*

