

# TAPER PIPE REAMERS NPFT (DRYSEAL) OR NPT

# CARBIDE TIPPED MORSE TAPER SHANK

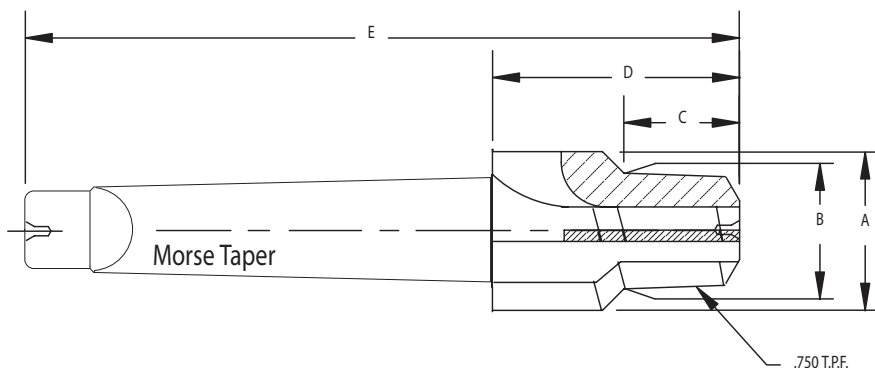

Pipe Tap Cutters will form in one pass a taper reamed and chamfered hole that mates with a tapered pipe thread tap. (For use in pre-drilled tubing or precast holes.) Substantially reduces premature tap wear and breakage. Cutter is completely form relieved for ease of sharpening.



COATINGS AVAILABLE	
TITANIUM NITRIDE-TIN	
TITANIUM CARBONITRIDE-TICN	
TITANIUM ALUMINUM NITRIDE-TIALN	
AL TITANIUM NITRIDE-ALTN	

## COOLANT THRU AVAILABLE

TOOL NUMBER	THREAD SIZE	A DIA.	B DIA.	C REAMER LENGTH	D HEAD LENGTH	E OAL	SHANK DIMENSIONS		NO. OF FLUTES
							MORSE TAPER NO.	SHANK LENGTH	
PR-00TS	1-16-27	5/8	.254	15/32	1-1/4	4-3/8	2	3-1/8	3
PR-01TS	1/8-27	5/8	.347	15/32	1-1/4	4-3/8	2	3-1/8	3
PR-02TS	1/4-18	3/4	.450	21/32	1-3/8	4-1/2	2	3-1/8	3
PR-03TS	3/8-18	7/8	.586	11/16	1-1/2	4-5/8	2	3-1/8	3
PR-04TS	1/2-14	1	.725	7/8	1-7/8	5	2	3-1/8	3
PR-05TS	3/4-14	1-1/4	.937	7/8	1-7/8	5-3/4	3	3-7/8	3
PR-06TS	1-11-1/2	1-1/2	1.173	1-1/16	2-1/8	6	3	3-7/8	3
PR-07TS	1-1/4-11-1/2	1-7/8	1.518	1-1/8	2-1/4	6-1/8	3	3-7/8	3
PR-08TS	1-1/2-11-1/2	2-1/8	1.757	1-1/8	2-1/2	6-3/8	3	3-7/8	4
PR-09TS	2-11-1/2	2-5/8	2.230	1-7/32	2-3/4	7-5/8	4	4-7/8	4
PR-10TS	2-1/2-8	3-1/8	2.670	1-3/4	3-1/8	8	4	4-7/8	4
PR-11TS	3-8	3-1/4	3.296	1-7/8	3-1/2	8-3/8	4	4-7/8	4

