

# TAPER PIPE REAMERS NPFT (DRYSEAL) OR NPT

# CARBIDE TIPPED STRAIGHT SHANK

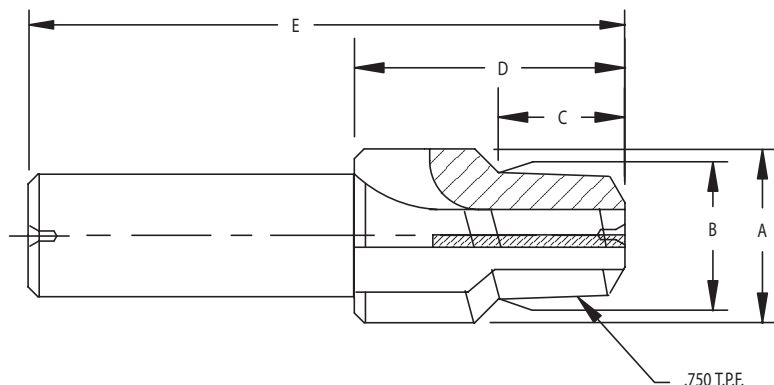

Pipe Tap Cutters will form in one pass a taper reamed and chamfered hole that mates with a tapered pipe thread tap. (For use in pre-drilled tubing or precast holes.) Substantially reduces premature tap wear and breakage. Cutter is completely form relieved for ease of sharpening.



## COATINGS AVAILABLE

TITANIUM NITRIDE-TIN  
TITANIUM CARBONITRIDE-TICN  
TITANIUM ALUMINUM NITRIDE-TIALN  
AL TITANIUM NITRIDE-ALTiN

## COOLANT THRU AVAILABLE

TOOL NUMBER	THREAD SIZE	A DIA.	B DIA.	C REAMER LENGTH	D HEAD LENGTH	E OAL	SHANK DIMENSIONS		NO. OF FLUTES
							DIAMETER	LENGTH	
PR-00T	1-16-27	5/8	.254	15/32	1-1/4	3-1/2	.750	2-1/4	3
PR-01T	1/8-27	5/8	.347	15/32	1-1/4	3-1/2	.750	2-1/4	3
PR-02T	1/4-18	3/4	.450	21/32	1-3/8	3-5/8	.750	2-1/4	3
PR-03T	3/8-18	7/8	.586	11/16	1-1/2	3-3/4	.750	2-1/4	3
PR-04T	1/2-14	1	.725	7/8	1-7/8	4-1/8	.750	2-1/4	3
PR-05T	3/4-14	1-1/4	.937	7/8	1-7/8	4-1/8	.750	2-1/4	3
PR-06T	1-11-1/2	1-1/2	1.173	1-1/16	2-1/8	4-5/8	1.000	2-1/2	3
PR-07T	1-1/4-11-1/2	1-7/8	1.518	1-1/8	2-1/4	4-3/4	1.000	2-1/2	3
PR-08T	1-1/2-11-1/2	2-1/8	1.757	1-1/8	2-1/2	5	1.000	2-1/2	4
PR-09T	2-11-1/2	2-5/8	2.230	1-7/32	2-3/4	5-1/4	1.000	2-1/2	4
PR-10T	2-1/2-8	3-1/8	2.670	1-3/4	3-1/8	5-5/8	1.000	2-1/2	4
PR-11T	3-8	3-1/4	3.296	1-7/8	3-1/2	7	1.000	2-1/2	4

