

METRIC PORT CONTOUR CUTTER INTERNAL STRAIGHT THREAD O-RING BOSS

HIGH SPEED STEEL
STRAIGHT SHANK

ISO 6149-1, SAE J2244 W/O ID GROOVE



Reamer pilot series porting tools profile the ISO 6149-1 contour. The reamer pilot also sizes the minor diameter per class 6H thread specification. Cutters are heat treated for toughness and durability. All tolerances are held within applicable ISO Specs. All grinding is done between centers to insure concentricity.

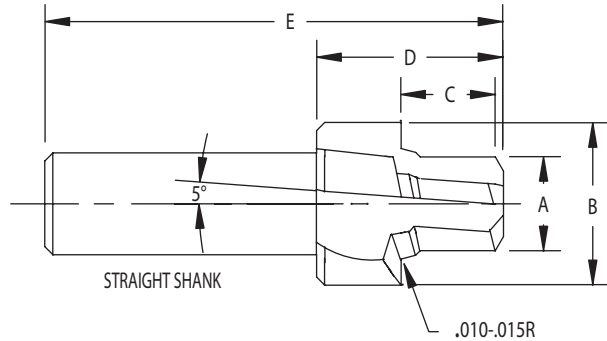

COATINGS AVAILABLE

- TITANIUM NITRIDE-TIN
- TITANIUM CARBONITRIDE-TICN
- TITANIUM ALUMINUM NITRIDE-TIALN
- AL TITANIUM NITRIDE-ALTN

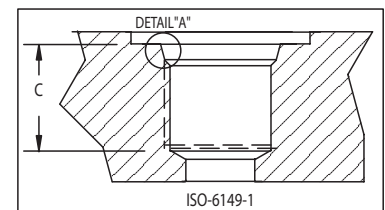
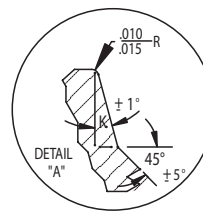

COOLANT THRU AVAILABLE

TOOL NUMBER	THREAD SIZE	A REAMER DIA.	B SPOTFACE DIA.	C REAMER LENGTH	D HEAD LENGTH	E OAL LENGTH	SHANK DIMENSIONS		K ANGLE	NO. OF FLUTES
							SHANK DIA.	SHANK LENGTH		
M1-08H	M 8X1	.277	.669	.453	1-1/8	3-1/8	.500	2	12	3
M1-10H	M 10X1	.356	.787	.453	1-1/4	3-1/4	.500	2	12	3
M1-12H	M 12X1.5	.415	.906	.551	1-1/4	3-1/4	.500	2	15	3
M1-14H	M 14X1.5	.493	.984	.551	1-1/4	3-1/4	.500	2	15	3
M1-16H	M 16X1.5	.572	1.102	.610	1-1/4	3-1/4	.500	2	15	3
M1-18H	M 18X1.5	.651	1.181	.669	1-3/8	3-3/8	.750	2	15	3
M1-20H	M 20X1.5	.730	1.260	.689	1-3/8	3-3/8	.750	2	15	3
M1-22H	M 22X1.5	.808	1.339	.709	1-5/8	3-5/8	.750	2	15	3
M1-27H	M 27X2	.985	1.575	.866	1-7/8	4-1/8	.750	2-1/4	15	3
M1-33H	M 33X2	1.221	1.929	.866	1-7/8	4-1/8	.750	2-1/4	15	3
M1-42H	M 42X2	1.576	2.362	.886	1-7/8	4-1/8	1.000	2-1/4	15	3
M1-48H	M 48X2	1.812	2.598	.984	2	4-1/4	1.000	2-1/4	15	4
M1-60H	M 60X2	2.284	2.992	1.083	2	4-1/4	1.000	2-1/4	15	4

