

# TREPAN CUTTER "O" RING GROOVE TOOL

# CARBIDE TIPPED STRAIGHT SHANK

Cutters are manufactured as carbide tipped only, 4 straight flutes with a 3/4" or 1" straight shank, depending on main cutter diameter.

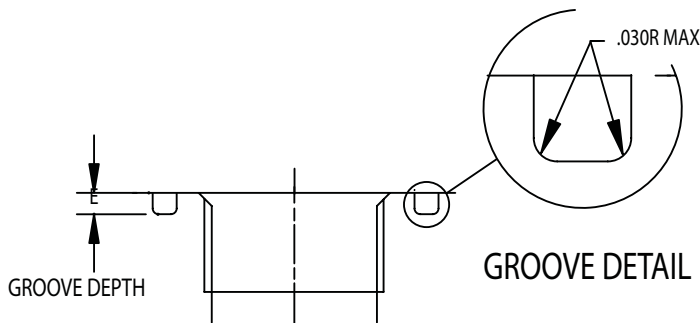
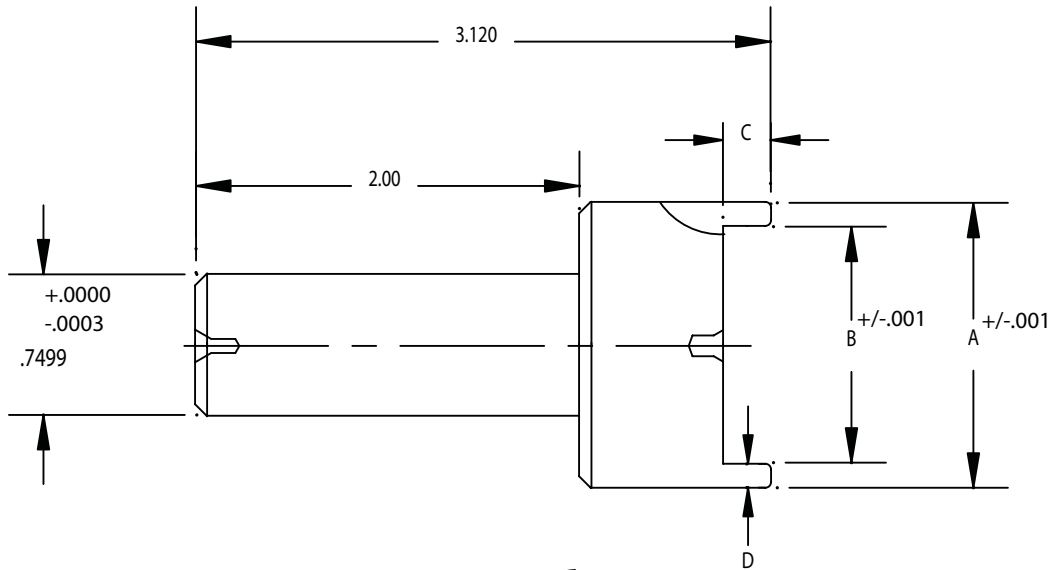

**A = LARGE DIAMETER**  
**B = INSIDE DIAMETER**  
**C = DEPTH OF CUT**  
**SPECIFY SHANK DIAMETER**

**TO RECEIVE A QUOTE, FILL IN THE INFORMATION BELOW AND FAX (815-393-3143) TO FORM RELIEF TOOL CO., INC**

\_\_\_\_\_ **A=LARGE DIAMETER**

\_\_\_\_\_ **B=INSIDE DIAMETER**

\_\_\_\_\_ **C=CARBIDE DEPTH**

\_\_\_\_\_ **D=GROOVE WIDTH**

\_\_\_\_\_ **E=GROOVE DEPTH**

COATINGS AVAILABLE
TITANIUM NITRIDE-TIN
TITANIUM CARBONITRIDE-TICN
TITANIUM ALUMINUM NITRIDE-TIALN
AL TITANIUM NITRIDE-ALTIN

