

# SAE SHORT PORT CONTOUR CUTTERS INTERNAL STRAIGHT THREAD O-RING BOSS

# CARBIDE TIPPED STRAIGHT SHANK

**MS16142 / J514 / J1926**

Plug Port series porting tools profile the MS16142/J514F/J1926 contour with a reduced spotface diameter. The reamer pilot also sizes the minor diameter per class 2B thread specification. Cutters are heat treated for toughness and durability. All tolerances are held within applicable Mil Specs. All grinding is done between centers to insure concentricity.



### COATINGS AVAILABLE

**TITANIUM NITRIDE-TIN  
TITANIUM CARBONITRIDE-TICN  
TITANIUM ALUMINUM NITRIDE-TIALN  
AL TITANIUM NITRIDE-ALTN**

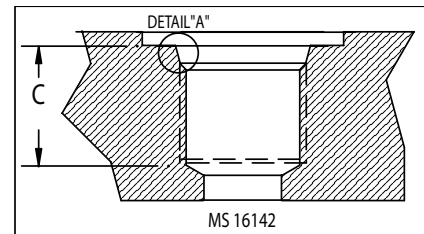
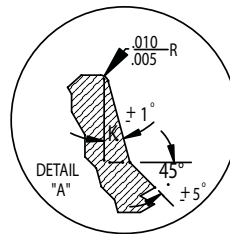
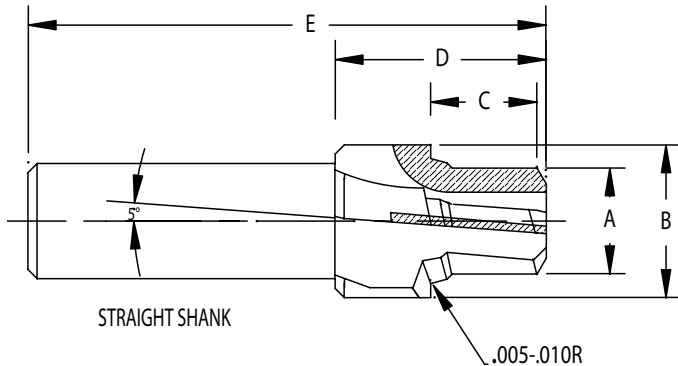

**COOLANT THRU AVAILABLE • All diameters and dimensions can be altered to meet your requirements**

TOOL NUMBER	TUBE NO.	TUBE SIZE	THREAD SIZE	A REAMER DIA.	B SPOTFACE DIA.	C REAMER LENGTH	D HEAD LENGTH	E OAL LENGTH	SHANK DIMENSIONS	
									SHANK DIA.	SHANK LENGTH
SP-02T	2	1/8	5/16-24	.272	.469	.473	1-1/8	3-1/8	.500	2
SP-03T	3	3/16	3/8-24	.335	.531	.473	1-1/4	3-1/4	.500	2
SP-04T	4	1/4	7/16-24	.389	.594	.552	1-1/4	3-1/4	.500	2
SP-05T	5	5/16	1/2-24	.452	.656	.552	1-1/4	3-1/4	.500	2
SP-06T	6	3/8	9/16-18	.509	.719	.614	1-1/4	3-1/4	.500	2
SP-08T	8	1/2	3/4-16	.689	.906	.693	1-3/8	3-3/8	.750	2
SP-10T	10	5/8	7/8-14	.806	1.031	.786	1-5/8	3-5/8	.750	2
SP-12T	12	3/4	1-1/16-12	.981	1.281	.911	1-7/8	4-1/8	.750	2-1/4
SP-14T	14	7/8	1-3/16-12	1.106	1.423	.911	1-7/8	4-1/8	.750	2-1/4
SP-16T	16	1"	1-5/16-12	1.231	1.562	.911	1-7/8	4-1/8	.750	2-1/4
SP-20T	20	1-1/4	1-5/8-12	1.544	1.910	.911	2	4-1/4	1.000	2-1/4
SP-24T	24	1-1/2	1-7/8-12	1.794	2.172	.911	2	4-1/4	1.000	2-1/4
SP-32T	32	2	2-1/2-12	2.419	2.797	.911	2-1/4	4-1/2	1.000	2-1/4

